

mounting direction

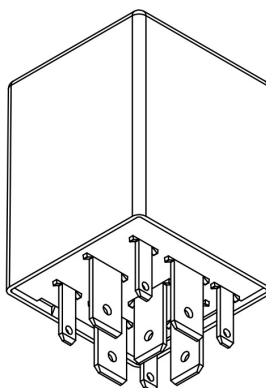

view of plug

DESCRIPTION

The Micro PLC CAN 4 I/O is a very small controller for automotive applications. The module is user configurable / programmable for a wide range of automotive applications. Control and data readout is via CAN bus.

TECHNICAL SPECIFICATION

Housing	Plastic PA66GF30
Connector	9-in bottom panel
Weight	28 g
Temperature range (according to ISO 16750-4)	-40 °C to + 85 °C (at +85 °C not full load)
Environmental protection	IP 53
Current consumption	24 mA (12 V); 26 mA (24 V)
Over-current Protection	10 A
Total Inputs and outputs	4 inputs/outputs (I/Os), 1 digital input
Inputs	Configurable as: Analog (0...11.4 V) Digital, positive encoder signals
Outputs	Configurable as: Digital, positiv switching (High-Side) PWM output (3 Hz...500 Hz)
Operating voltage	9 V to 32 V 12 V (Code C) and 24 V (Code E) acc. to ISO 16750 - 2
Starting voltage	8 V
Overvoltage protection	≥ 33 V
Undervoltage cut-off	≤ 6 V
Quiescent current	300 µA (12 V); 460 µA (24 V)
Reverse polarity protection	Yes
CAN Interfaces	CAN Interface 2.0 A/B ISO 11898-2:2006

REGULATORY APPROVALS AND TESTING

E1 approval	ECE R10 04 7199
Electrical tests	Acc. to ISO 16750-2:2012: Reverse Polarity Short circuit Long-term span at T + 60 °c Storage Test at T + 85 °c and T-40 °c Surgical Test at T-40 °c Superimposed alternating voltage Slow lowering and rising of the supply voltage Reset behavior in case of voltage drop Noise emission/immunity to ECE R10 Rev. 04 Cable-led interference emission to ECE R10 Rev. 04 Pulse 1, 2a, 2b, 3a, 3b and 4 according to ISO 7637-2:2004

SOFTWARE/PROGRAMMING

Programming System	MRS Developers Studio MRS Developers Studio with built-in functions library, similar programming with FUP. Custom software blocks can be integrated into "C-code". Program memory is sufficient for about 300 basic logic components.
--------------------	---



INPUT FEATURES - SUMMARY

Pin 1, 3, 5, 8	Usable as analog or digital input		Pin 4	Usable as analog or digital input	
	Resolution	12 Bit		Resolution	12 Bit
	Accuracy	±1 % full scale		Accuracy	±1 % full scale
Voltage input 0...11.4 V (see A)	Input resistance	17.6 kΩ	Voltage input 0...11.4 V (see A)	Input resistance	22.6 kΩ
	Input frequency	60 Hz		Input frequency	60 Hz
	Accuracy	±3 %		Accuracy	±3 %
Digital input Positive (see B)	Input resistance	17.6 kΩ	Digital input Positive (see A)	Input resistance	22.6 kΩ
	Input frequency			Input frequency	
	Turn-on threshold	6.5 V		Turn-on threshold	6.5 V
	Turn-off threshold	4.9 V		Turn-off threshold	4.9 V

¹ cutoff frequency (-3 dB)

OUTPUT FEATURES - SUMMARY

Pin 1, 3, 5, 8	Protective circuit for inductive loads	integrated	PWM-output (see C)	Output frequency	3...500 Hz
	Wire fault diagnostics	Possible via current sense		Duty cycle	0...1000 ‰
	Short circuit diagnostics	Possible via current sense		Resolution	1 ‰
Digital, positive switching (high side; see B)	Switching voltage	9-32 V DC	Short circuit protection against ground and V _b	Switching current	bis 2.5 A
	Switching current	0.02...2.5 A		Switching-off is controlled via low side driver (separate for each channel)	
	Read off current	Via signal AI_I_87, AI_I_87A, AI_I_C, AI_I_X Calibrated values can be activated / deactivated via ALG_CAL_STATE in MRS Developers Studio			

PERFORMANCE TEST OUTPUTS AT T_{MAX}

Test without PWM	Test No.	Load	Duration
	1	4 x 2 A	permanent
	2	1 x 2.5 A (87A); 2 x 1 A (X, 87)	30 min
	3	1 x 3 A (87)	15 min

PIN ASSIGNMENT POWER SUPPLY AND INTERFACES

Pin	Pin description	Pin	Pin description
2	Supply voltage	7	CAN - H
4	Battery/ignition contact 15 / analog / digital input	9	CAN - L
6	Ground		

PIN ASSIGNMENT INPUTS AND OUTPUTS

Pin	Programm signal	Pin description	Pin	Programm signal	Pin description
1	X	Analog/digital input X 0-11.4 V or digital output X with PWM option and read off current	5	87A	Analog/digital input 87A 0-11.4 V or digital output 87A with PWM option and read off current
3	C	Analog/digital input C 0-11.4 V or digital output C with PWM option and read off current	8	87	Analog/digital input 87 0-11.4 V or digital output 87 with PWM option and read off current

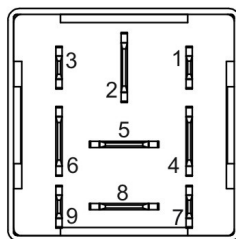

bottom view



PIN FEATURE MAP

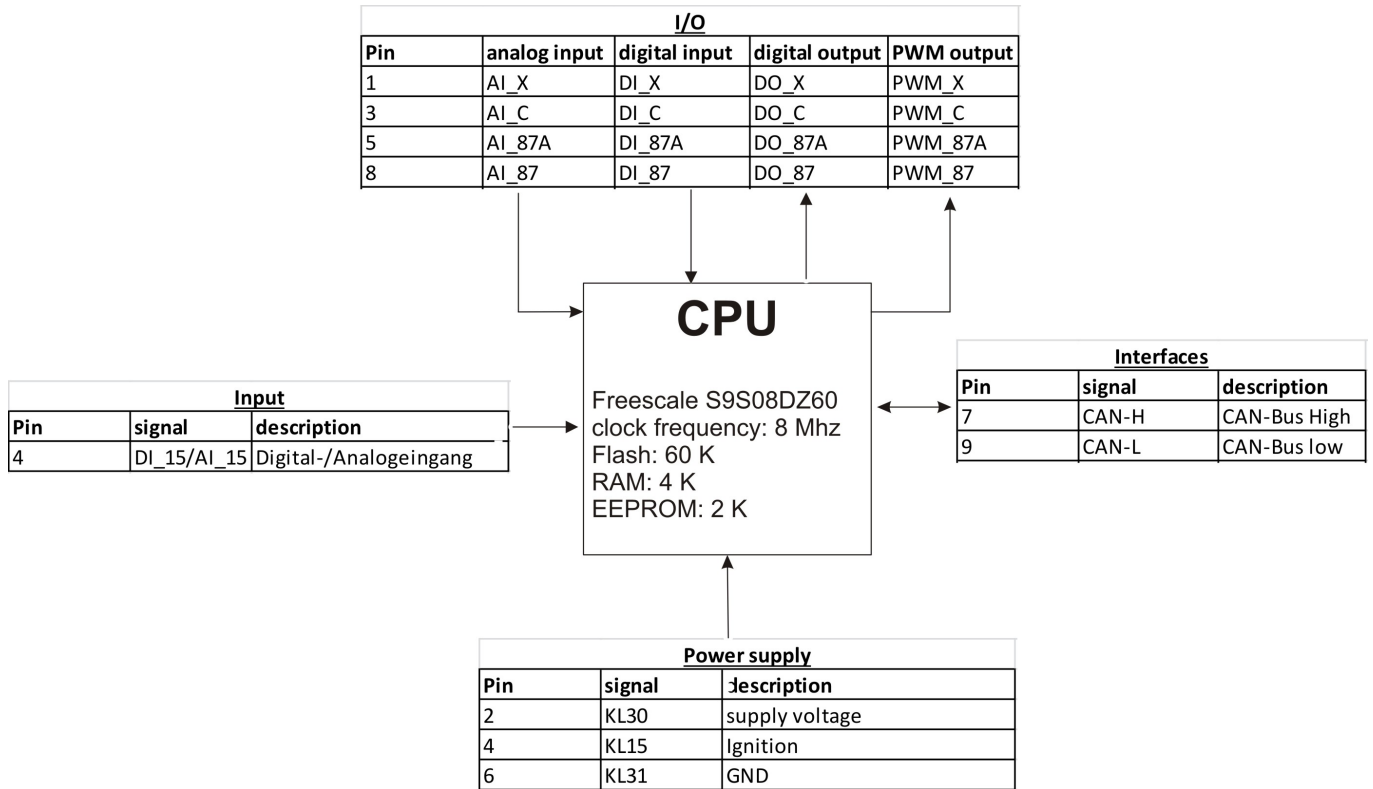

BLOCK FUNCTION DIAGRAM

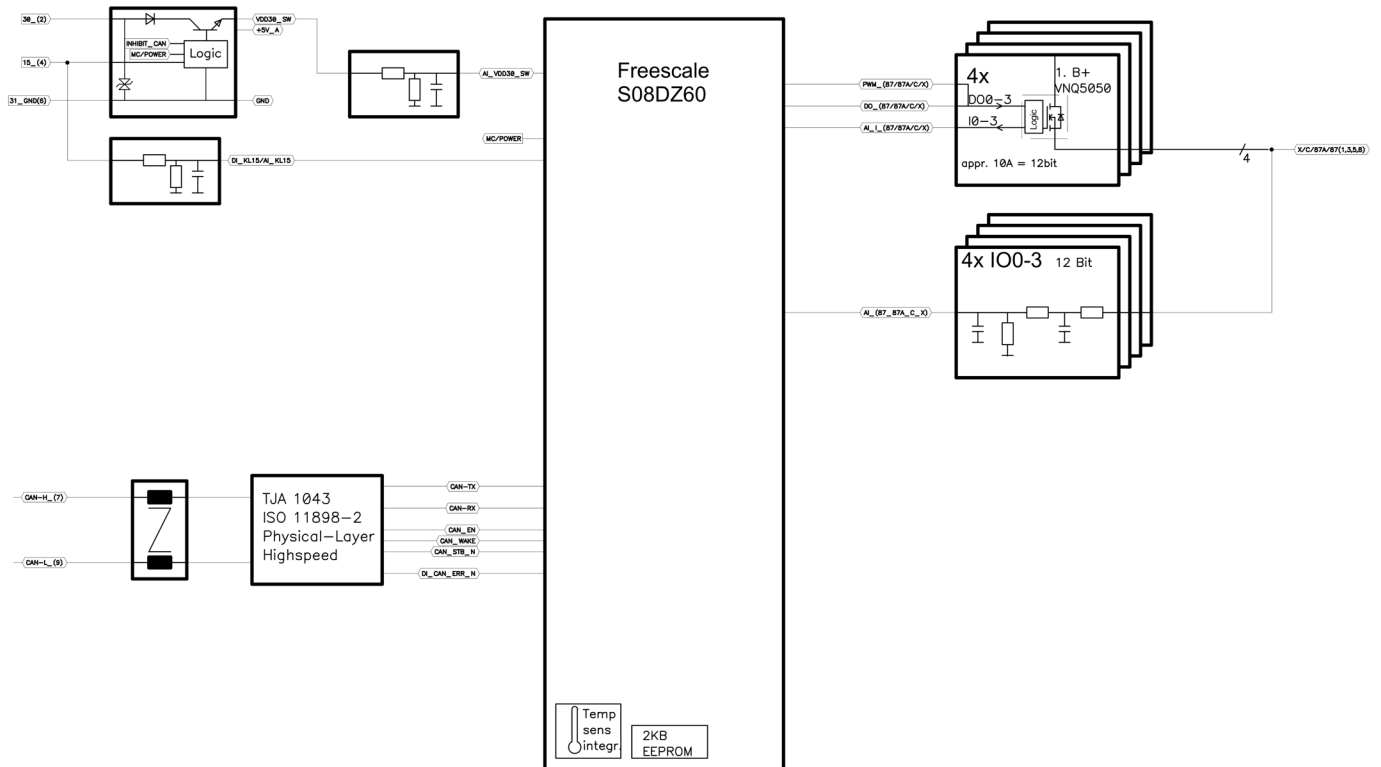

TECHNICAL DRAWING (IN MM)

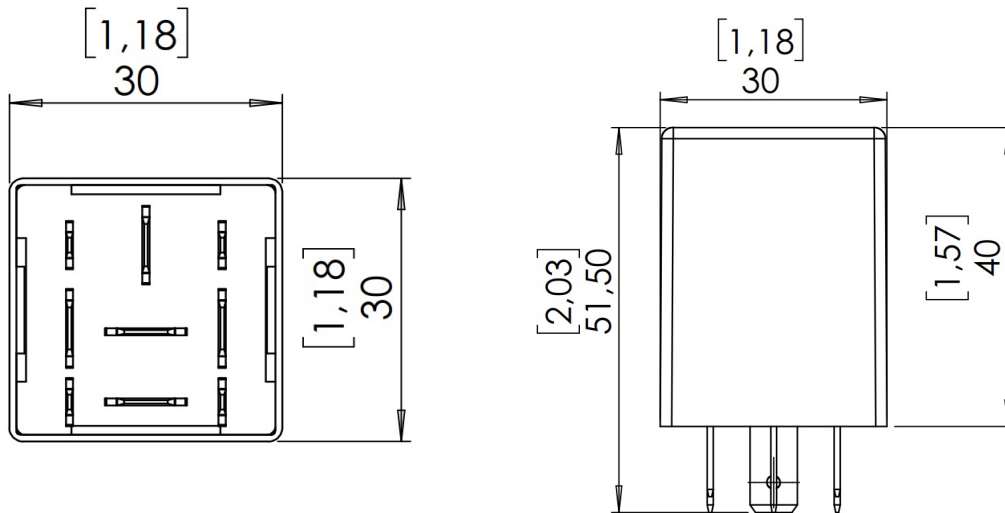



ASSEMBLY OPTIONS AND ORDER INFORMATION

	Inputs		Outputs	CAN Bus	
	A Voltage 0 – 11.4 V	B I/O's (optional as analog/digital input or digital output)	C PWM ≤ 500 Hz	High-Speed	Low-Speed
1.111.311.00	1, 3, 5, 8	1, 3, 5, 8	1, 3, 5, 8	X	

ACCESSORIES

Description	Order number
Softwaretool MRS Developers Studio	1.100.100.09
Socket ST FL 9-pin 5x6.3 / 4x2.8	1.017.002.00
Cable set to programm Micro PLC CAN / Prop CAN	109446
FASTON terminal 6.3 mm 1.5-2.5 mm ²	103064
FASTON terminal for latching 6.3mm 1mm ²	102355
FASTON terminal 2.8 mm 0.5-1.0 mm ²	105292
Housing bracket	1.017.080.00
PCAN-USB Interface	105358



MANUFACTURER

MRS Electronic GmbH & Co. KG
 Klaus-Gutsch-Str. 7
 78628 Rottweil

NOTES ON WIRING AND CABLE ROUTING

PWM outputs may not be connected with each other or bypassed.

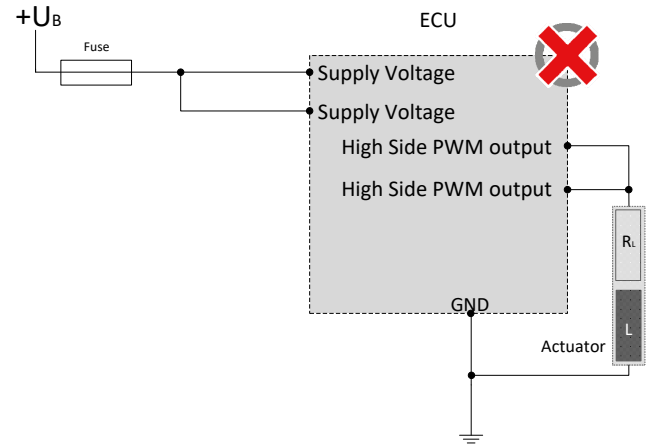
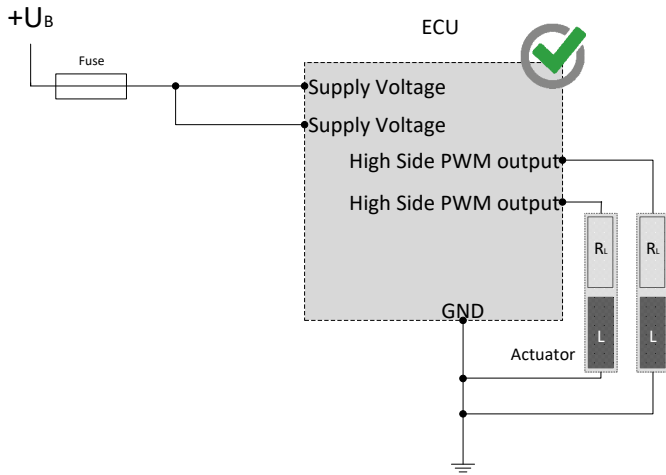

The pins (I/Os) can be used in combination and may not be switched externally against supply voltage.

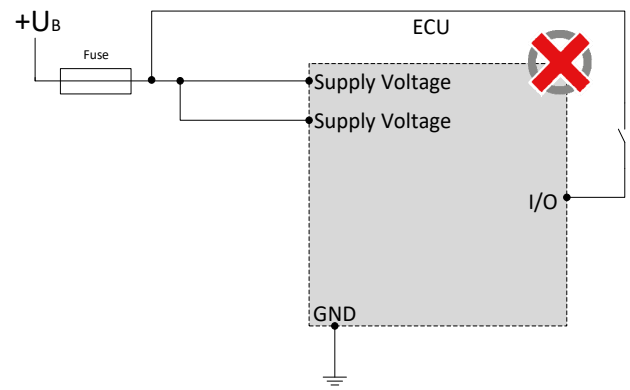
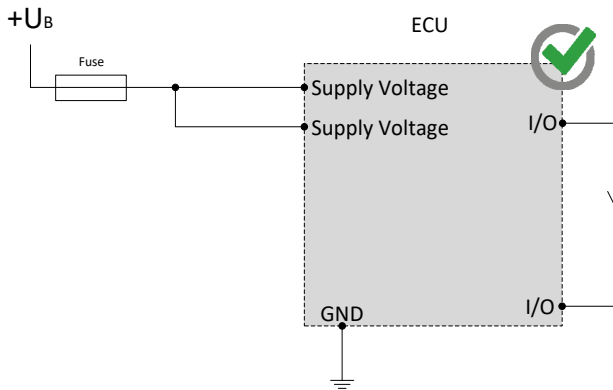

NOTES ON WIRING AND CABLE ROUTING

Hightside outputs may only be switched to ground.

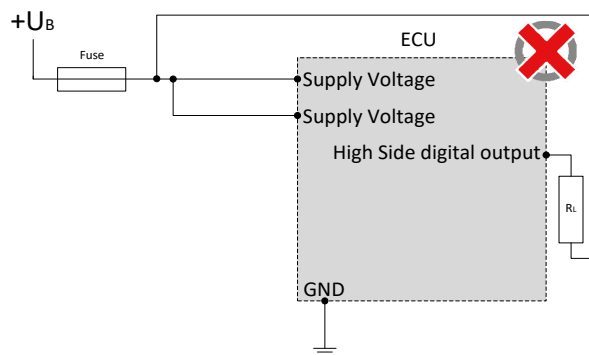
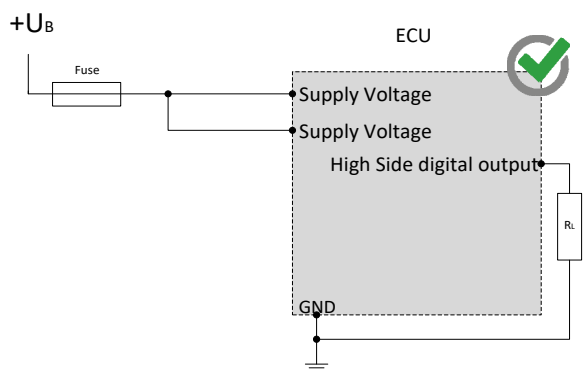
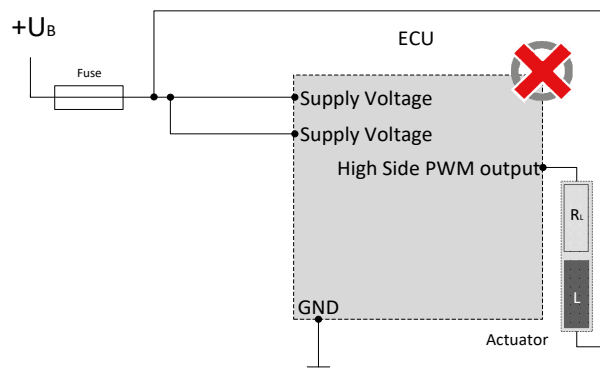
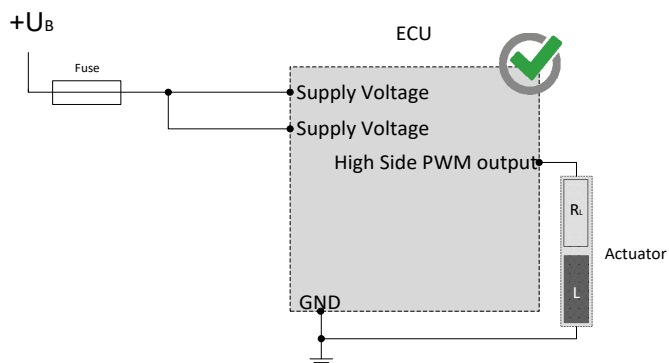

CAN bus communication is the main communication between the control unit and the vehicle. Therefore, connect the CAN bus with special care and check the correct communication with the vehicle to avoid undesired behavior.

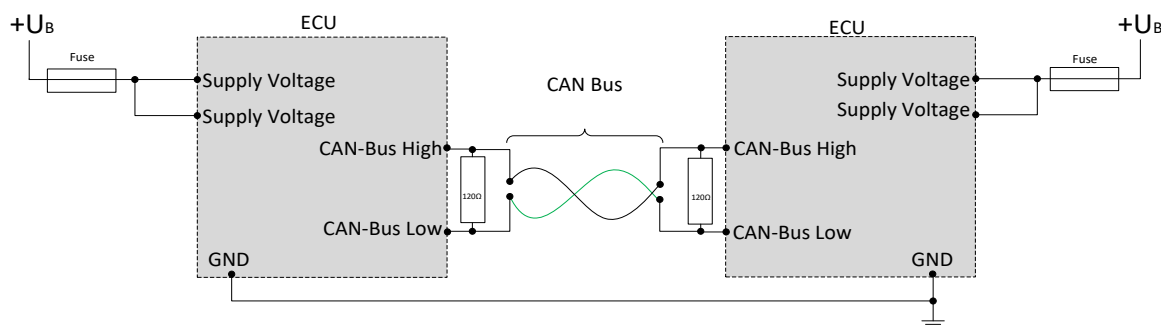

SAFETY AND INSTALLATION INFORMATION

It is essential to read the instructions in full thoroughly before working with the device.

Please note and comply with the instructions in the operating instructions and the information in the device data sheet, see www.mrs-electronic.de

Staff qualification: Only staff with the appropriate qualifications may work on this device or in its proximity.

SAFETY



WARNING! Danger as a result of a malfunction of the entire system.

Unforeseen reactions or malfunctions of the entire system may jeopardise the safety of people or the machine.

- Ensure that the device is equipped with the correct software and that the wiring and settings on the hardware are appropriate.



WARNING! Danger as a result of unprotected moving components.

Unforeseen dangers may occur from the entire system when putting the device into operation and maintaining it.

- Switch the entire system off before carrying out any work and prevent it from unintentionally switching back on.
- Before putting the device into operation, ensure that the entire system and parts of the system are safe.
- The device should never be connected or separated under load or voltage.



CAUTION! Risk of burns from the housing.

The temperature of the device housing may be elevated.

- Do not touch the housing and let all system components cool before working on the system.

PROPER USE

The device is used to control or switch one or more electrical systems or sub-systems in motor vehicles and machines and may only be used for this purpose. The device may only be used in an industrial setting.



WARNING! Danger caused by incorrect use.

The device is only intended for use in motor vehicles and machines.

- Use in safety-related system parts for personal protection is not permitted.
- Do not use the device in areas where there is a risk of explosion.

Correct use:

- operating the device within the operating areas specified and approved in the associated data sheet.
- strict compliance with these instructions and no other actions which may jeopardise the safety of individuals or the functionality of the device.

Obligations of the manufacturer of entire systems

It is necessary to ensure that only functional devices are used. If devices fail or malfunction, they must be replaced immediately.

System developments, installation and the putting into operation of electrical systems may only be carried out by trained and experienced staff who are sufficiently familiar with the handling of the components used and the entire system.

It is necessary to ensure that the wiring and programming of the device does not lead to safety-related malfunctions of the entire system in the event of a failure or a malfunction. System behaviour of this type can lead to a danger to life or high levels of material damage.

The manufacturer of the entire system is responsible for the correct connection of the entire periphery (e.g. cable cross sections, correct selection/connection of sensors/actuators).

Opening the device, making changes to the device and carrying out repairs are all prohibited. Changes or repairs made to the cabling can lead to dangerous malfunctions. Repairs may only be carried out by MRS.

Installation

The installation location must be selected so the device is exposed to as low a mechanical and thermal load as possible. The device may not be exposed to any chemical loads.

Install the device in such a manner that the plugs point downwards. This means condensation can flow off the device. Single seals on the cables/leads must be used to ensure that no water gets into the device.

Putting into operation

The device may only be put into operation by qualified staff. This may only occur when the status of the entire system corresponds to the applicable guidelines and regulations.

FAULT CORRECTION AND MAINTENANCE



NOTE The device is maintenance-free and may not be opened.

- If the device has damage to the housing, latches, seals or flat plugs, it must be taken out of operation.

Fault correction and cleaning work may only be carried out with the power turned off. Remove the device to correct faults and to clean it.

Check the integrity of the housing and all flat plugs, connections and pins for mechanical damage, damage caused by overheating, insulation damage and corrosion. In the event of faulty switching, check the software, switches and settings.

Do not clean the device with high pressure cleaners or steam jets. Do not use aggressive solvents or abrasive substances.